

---

## Study of In-Medium $\phi$ Meson Modification

via  $\phi \rightarrow K^+ K^-$  Measurement at J-PARC E88/SAΦRE

---



**WooSeung Jung (JAEA ASRC)**  
for the J-PARC  
E88/SAΦRE Collaboration



# Study of In-medium Modification of $\phi$ mesons

## Chiral symmetry breaking in QCD

- $\langle \bar{q}q \rangle$  depends on temperature and density
- Partially restored in nuclear matter
- $\phi$  meson: almost pure  $s\bar{s}$  state and narrow width (clean probe)

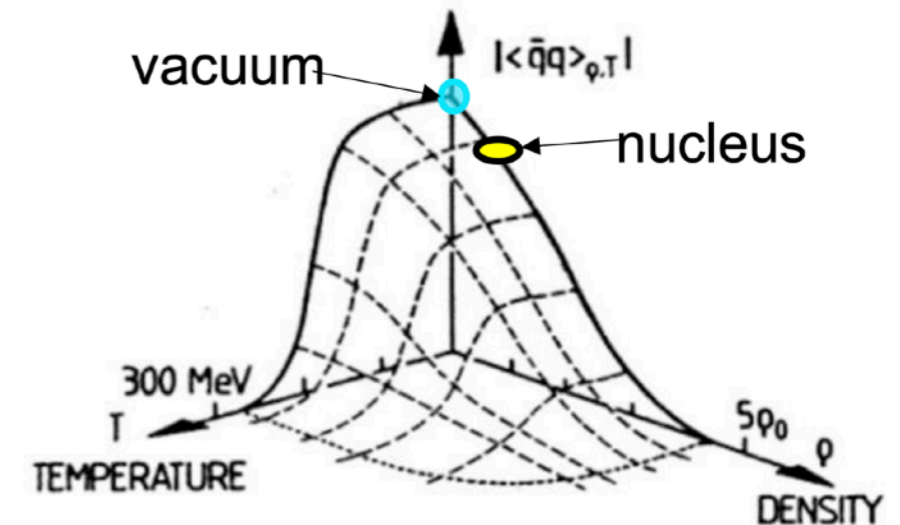

## Past experiment results

- No significant mass shift observed in p+A, A+A and  $\gamma$ +A collisions in  $\phi \rightarrow K^+K^-$  and  $e^+e^-$
- **KEK-325(p+A)**: Low-mass excess observed in  $\phi \rightarrow e^+e^-$  in low- $\beta\gamma$  ( $\beta\gamma < 1.25$ , p+Cu)

## Toward a definitive conclusion

High-statistics measurement at J-PARC E88 / E16  
 $\phi \rightarrow K^+K^-/e^+e^-$

## KEK-E325

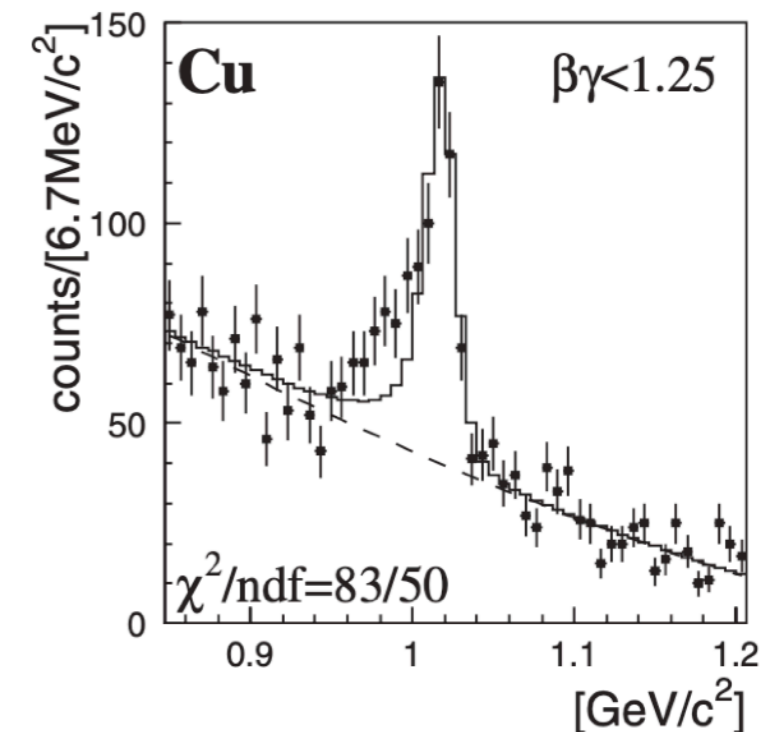

# E88/SAΦRE: High-statistics Study of $\phi \rightarrow K^+K^-$ Decays in Nuclear Matter

E88 aims to perform a precise measurement of  $\phi \rightarrow K^+K^-$  in **low- $\beta\gamma$  region** using a 30 GeV( $10^9$  protons/spill) beam at J-PARC

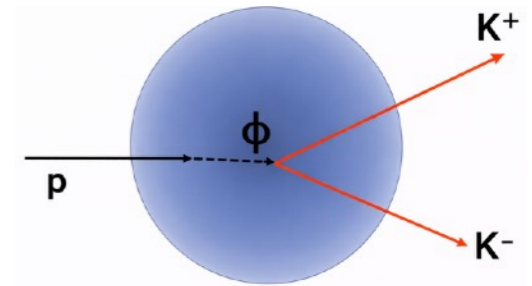

(Target: C, Cu, Pb)

Expected **J-PARC E88 sensitivity** compared with KEK-E325

- **2-order higher statistics** of  $\phi \rightarrow K^+K^-$  than KEK-E325
- **$\sim 500k$   $\phi \rightarrow K^+K^-$  events** at  $\beta\gamma < 1.25$  (No data in KEK-E325)
- complementary probe to  $\phi \rightarrow e^+e^-$  (J-PARC E16)

$\phi \rightarrow K^+K^-$  in KEK-E325

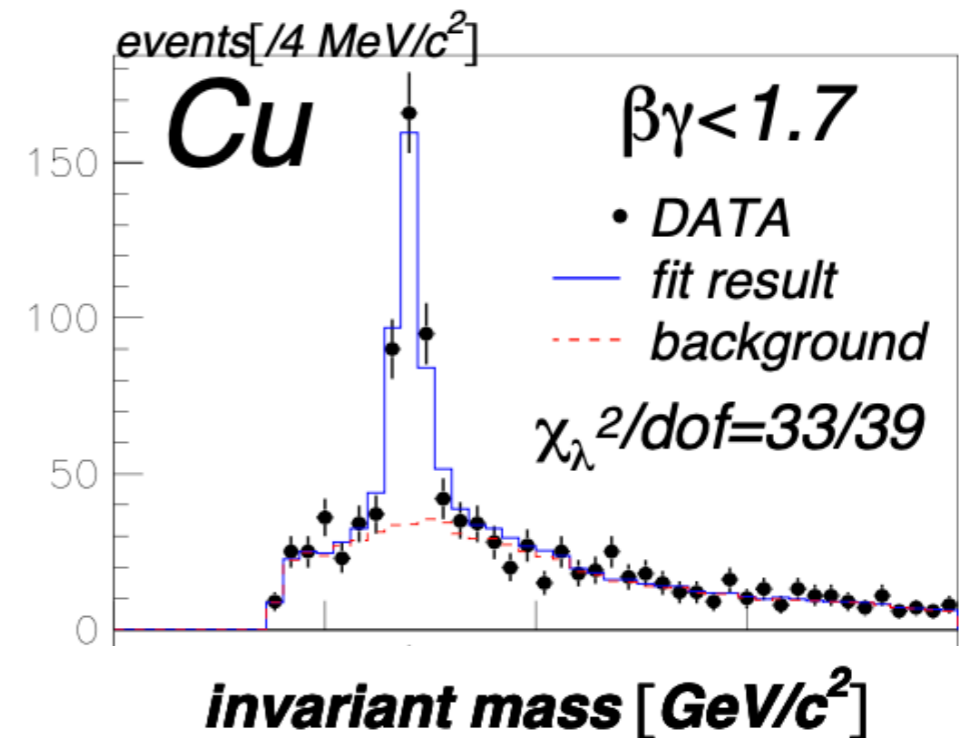

\*F. Sakuma et. al., PRL 98 152302 (2007) (KEK-E325)

# Longitudinal and Transverse $\phi$ Separation in E88

Decays angular distributions in  $\phi$  helicity rest frame for transverse (T,  $|1, \pm 1\rangle$ ) and longitudinal (L,  $|1, 0\rangle$ ) polarizations

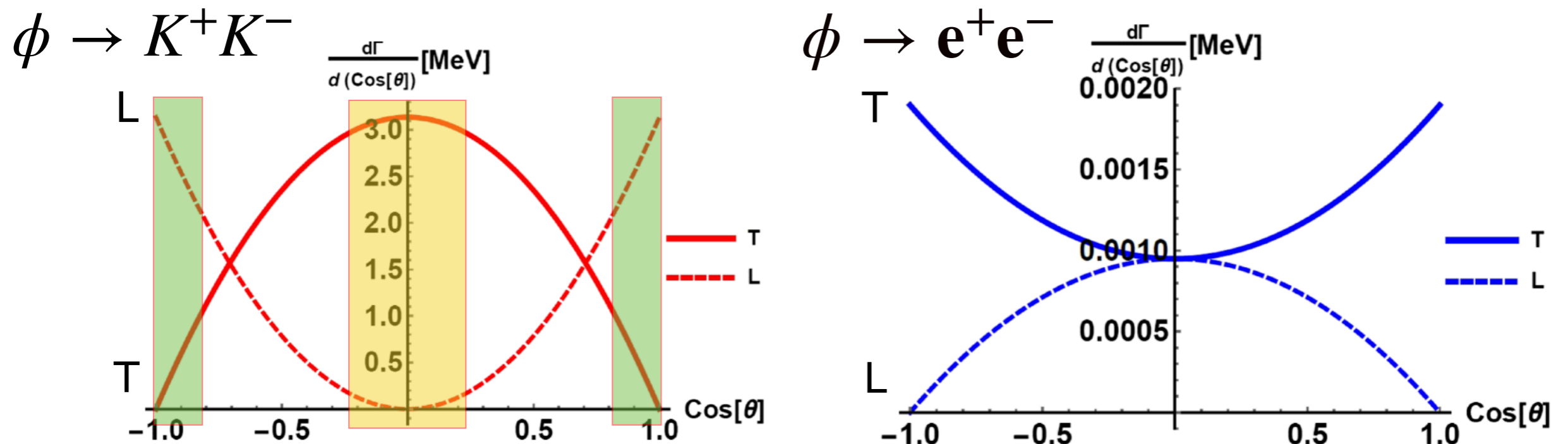

- In  $\phi \rightarrow K^+K^-$  decays, longitudinal ( $|\cos\theta| \approx 1$ ) and transverse ( $\cos\theta \approx 0$ ) rich events can be selected using decay angle.
- In  $\phi \rightarrow e^+e^-$  decays, it is hard to separate longitudinal component

\*I.W. Park, H. Sako, K. Aoki, P. Gubler and S.H. Lee, PRD 107, 074033 (2023)

# Predicted Momentum and Polarization Dependent Mass shift

## QCD sum-rule prediction for $\phi$ meson

\*H.J. Kim and P. Gubler, PLB 805, 135412 (2020)

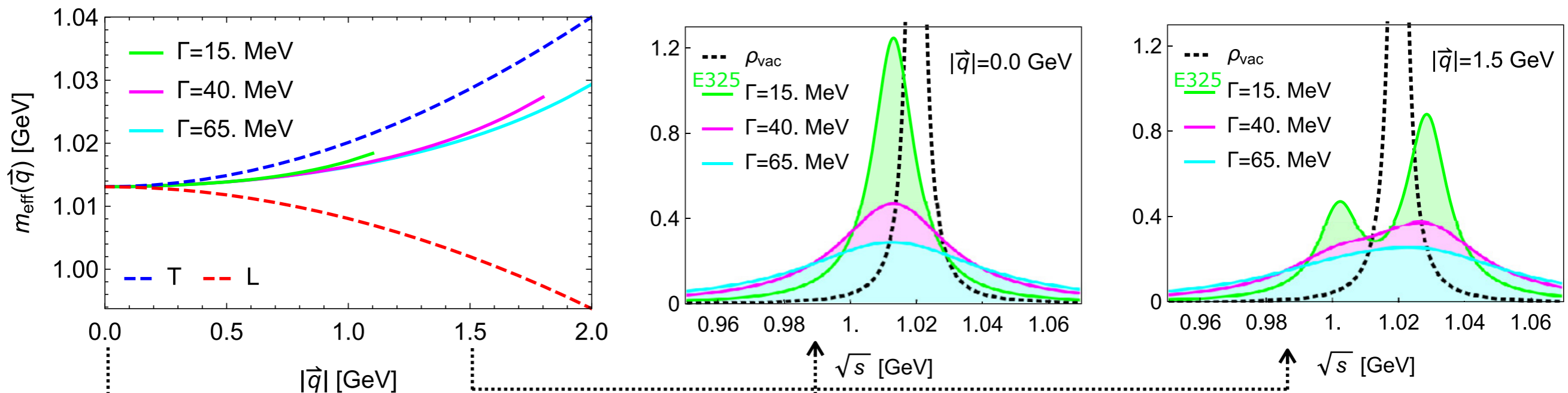

- Recent QCD sum-rule calculations predict **an in-medium mass shift** that is strongly correlated with the decrease of **the  $\langle \bar{s}s \rangle$  condensate** at finite density
- At finite momentum, the in-medium modification becomes **polarization dependent**, leading to opposite mass shifts.
- E88 provides a unique opportunity to test **polarization-dependent in-medium modifications** of the  $\phi$  meson.

# J-PARC E88 Spectrometer

- J-PARC E16 spectrometer is designed  $\phi \rightarrow e^+e^-$  measurement including particle tracking and hadron blinding.
- J-PARC E88 is performed based on E16 spectrometer. Kaon Identification System will be added on the upper and lower.
- Acceptance overlap between  $\phi \rightarrow K^+K^-$  and  $e^+e^-$

## E16 spectrometer configuration

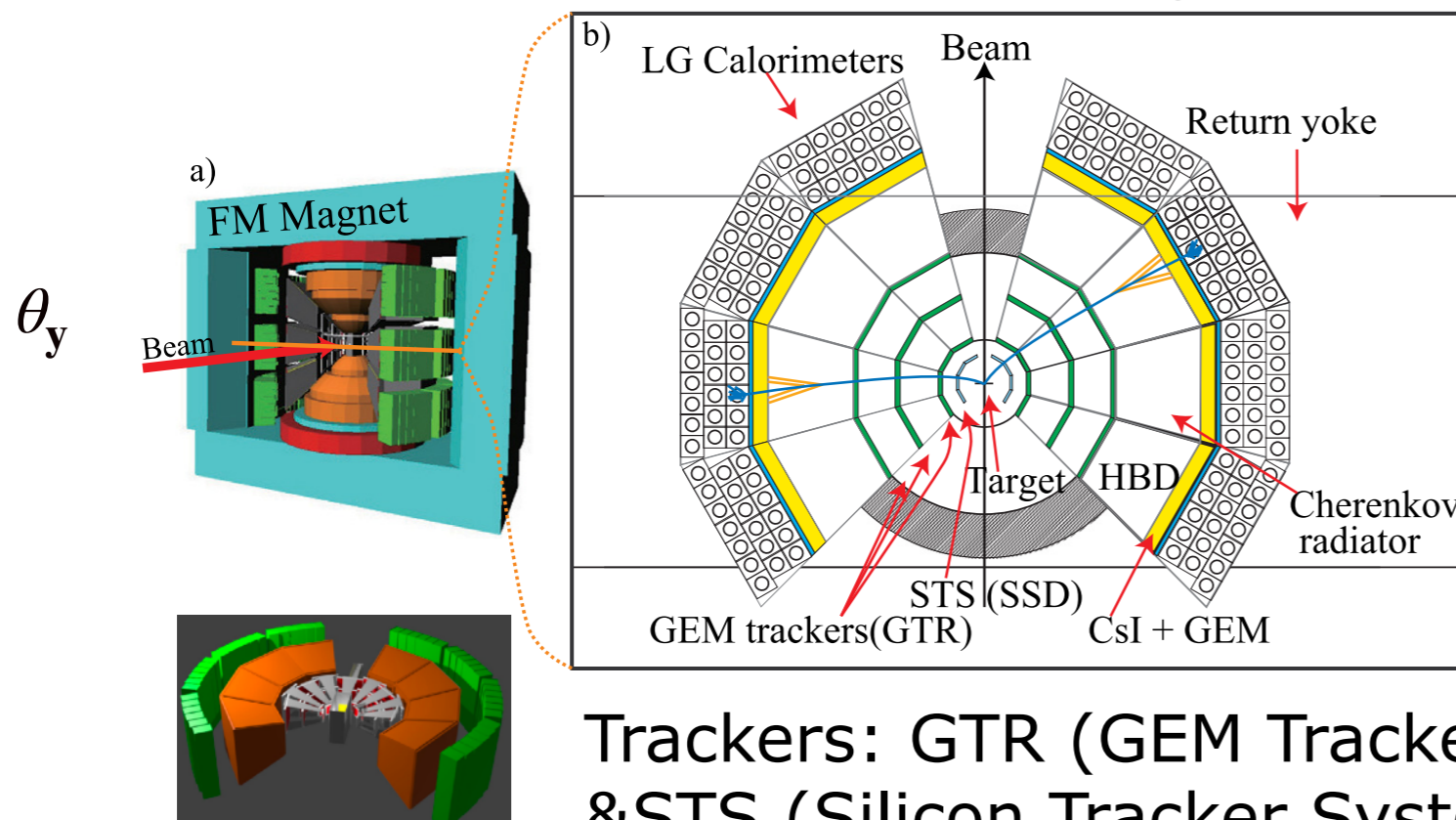

## E88 detector position

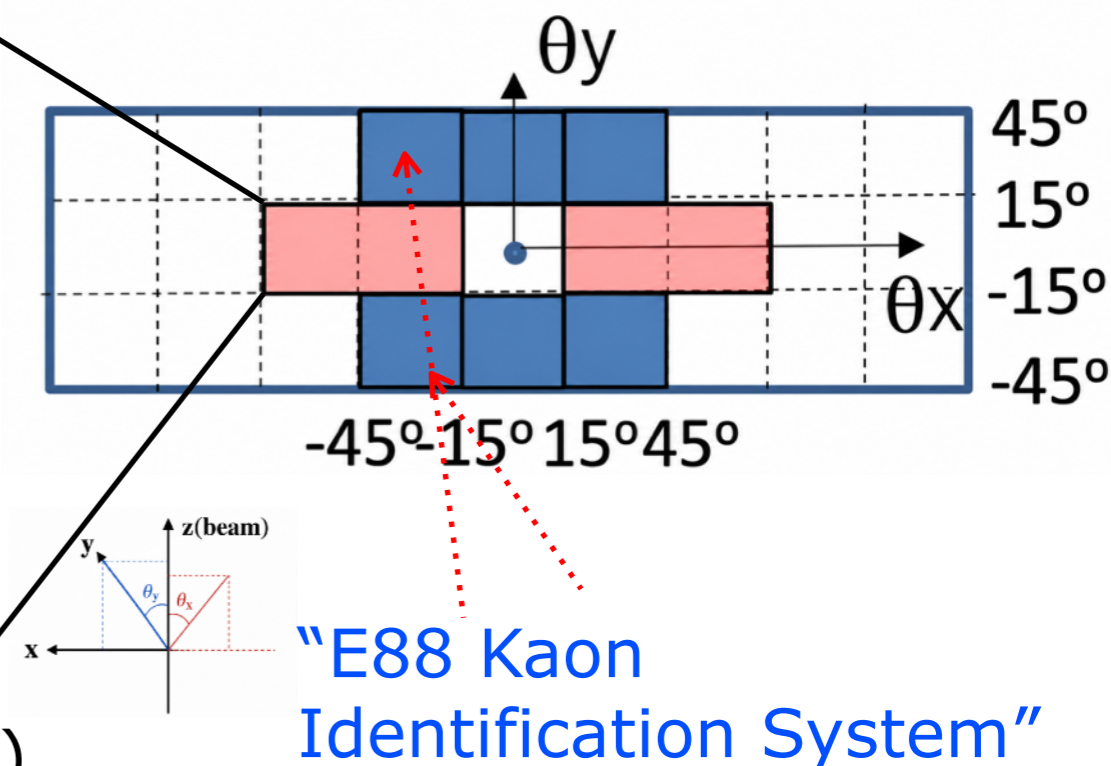

# Kaon Identification System of J-PARC E88

## E88 detector system with E16 spectrometer (Top and bottom layers)

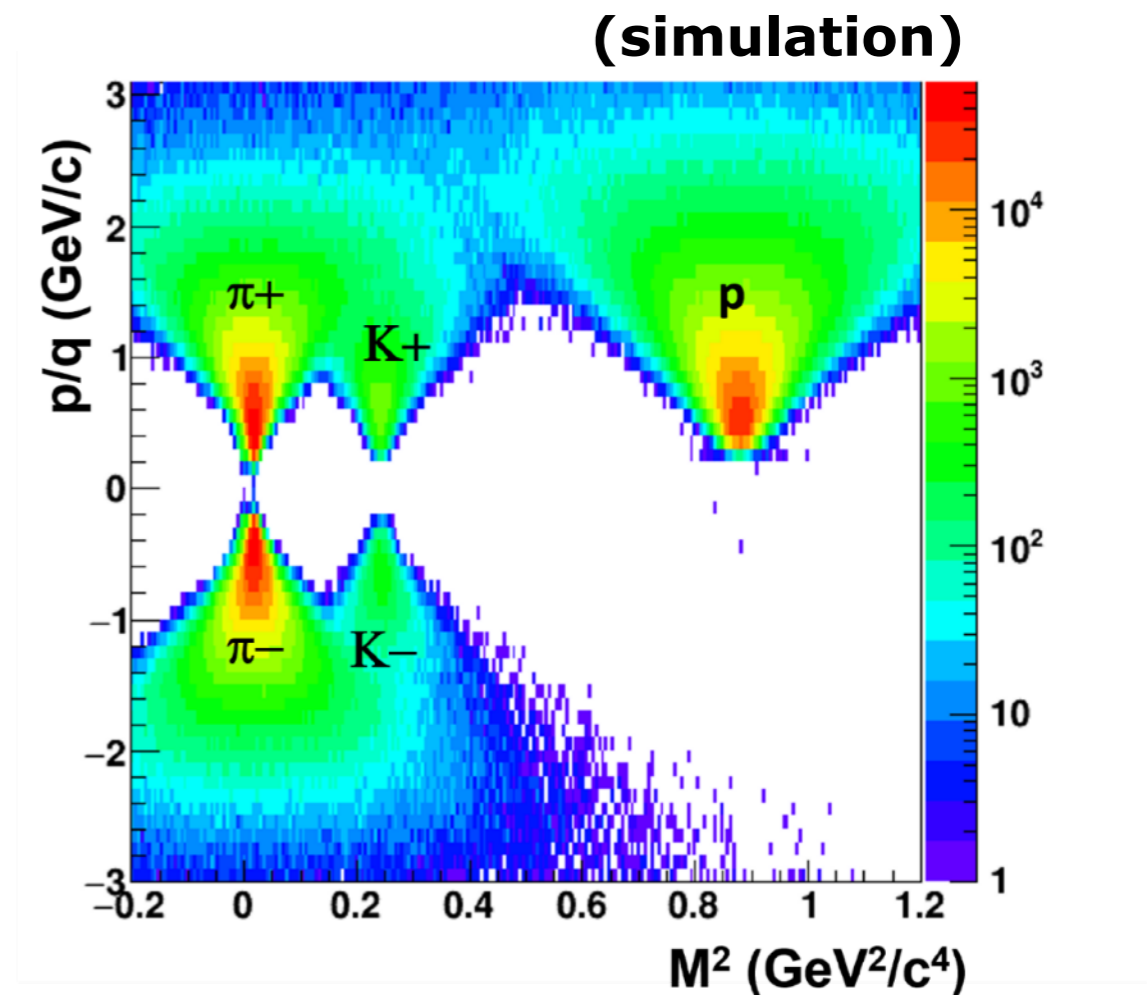
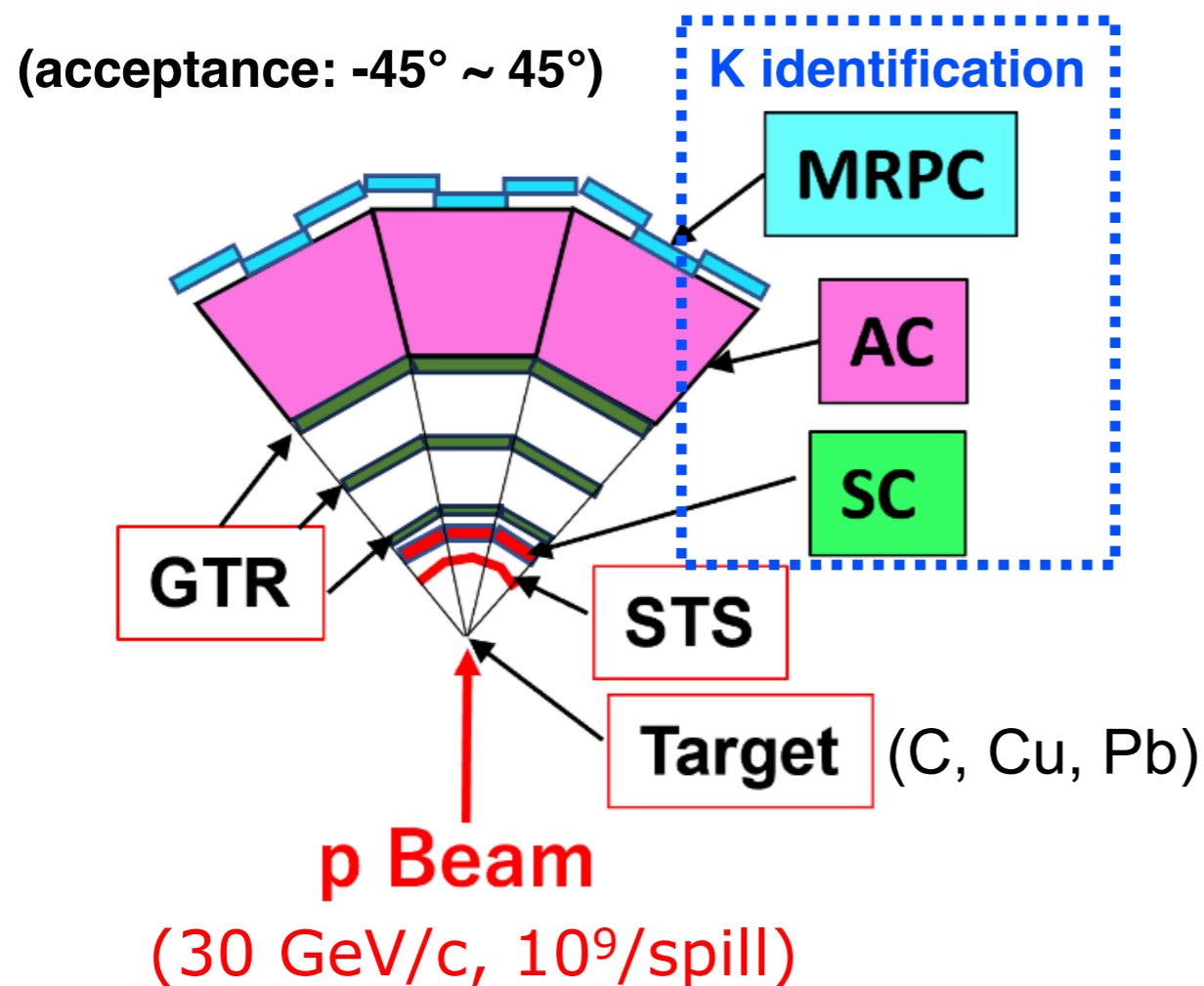

TOF: MRPC(Multi-gap Resistive Plate Chamber), SC(Start-timing Counter)

Background(low- $\beta\gamma$  suppression): AC(Aerogel Cherenkov Counter)

DAQ: streaming DAQ system(AMANEQ) -> More physics opportunities!

Possible upgrade with the sPHENIX INTT(Solid-state Strip Detector)

# Components of the E88 Kaon Identification System

## MRPC(Mult-gap Resistive Plate Chamber)

- High-rate capability using **heated glass**:  
~10% better time resolution at +20°C operation
- Time resolution:  $\sigma_T = 81 \pm 3 \text{ ps}$

## AC(Aerogel Cherenkov Counter)

- Refractive index: 1.15
- ~90% of detection efficiency in cosmic-ray tests

## Start-timing Counter (SC)

- 8x8x180 mm<sup>3</sup> plastic scintillation counters readout by S13360-3050 MPPCs.
- Time resolution:  $\sigma_T = 79 \pm 3 \text{ ps}$

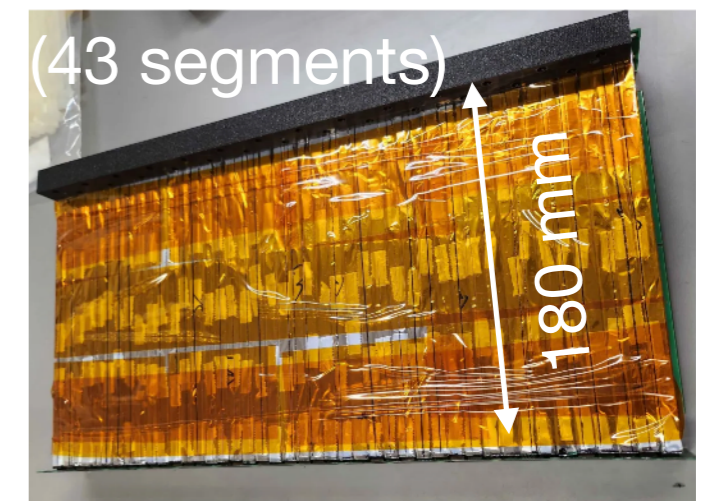
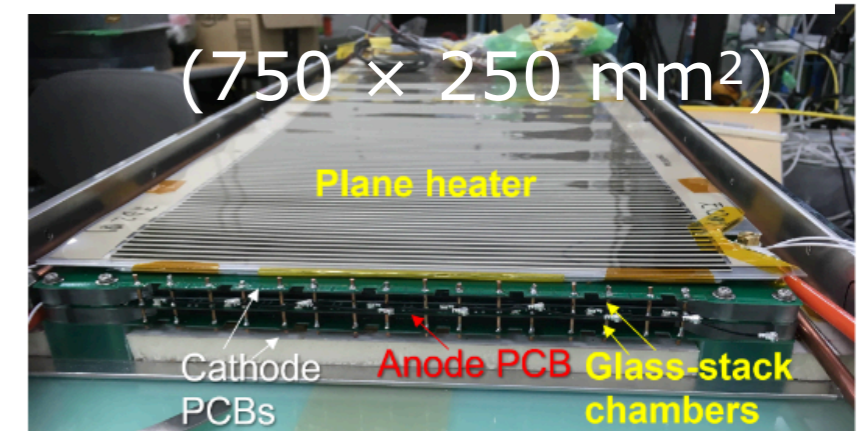
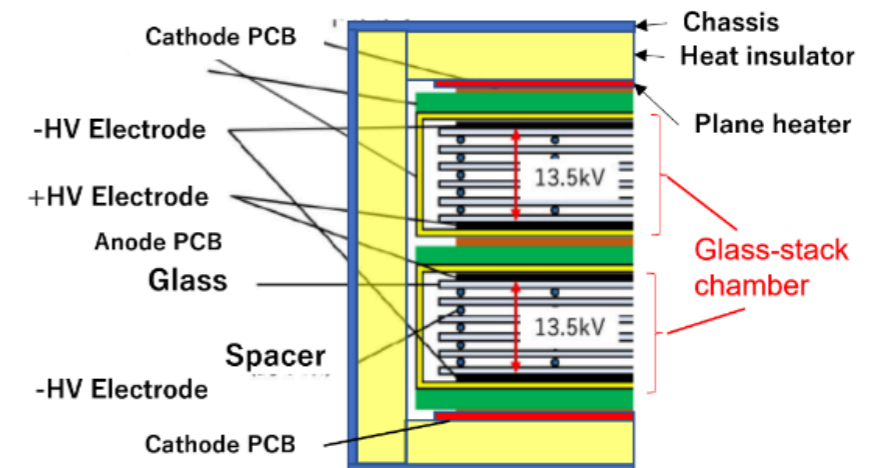

# 1st Commissioning of the J-PARC E88 Detector (April-June 2024)

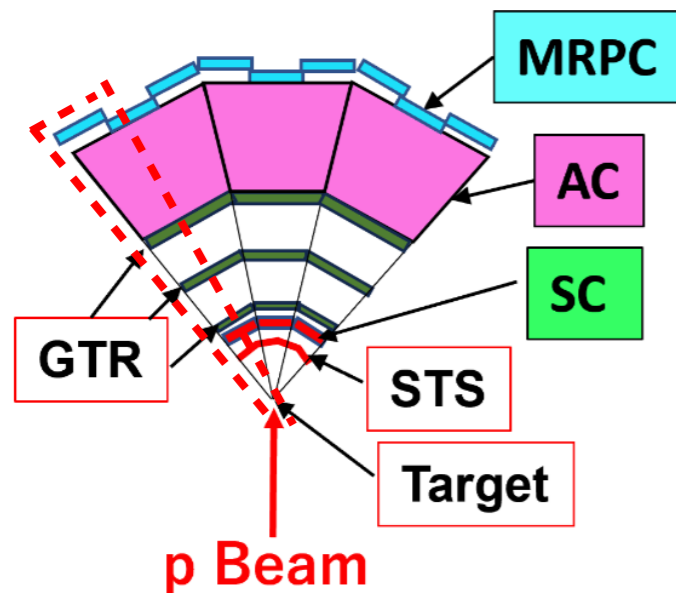

- A 1/24-scale prototype of the kaon identification system was tested in the E16
- Preliminary  $K/\pi/p$  separation achieved using prototype SC, MRPC

Time-of-flight between SC and MRPC

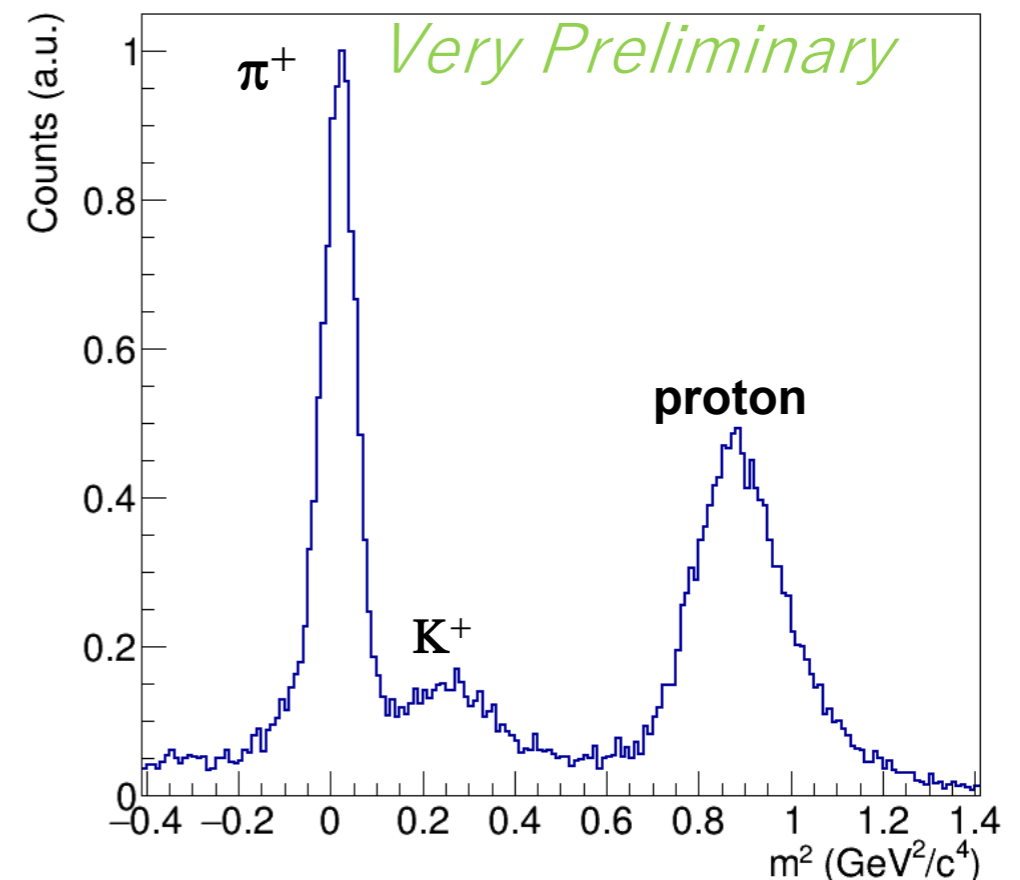
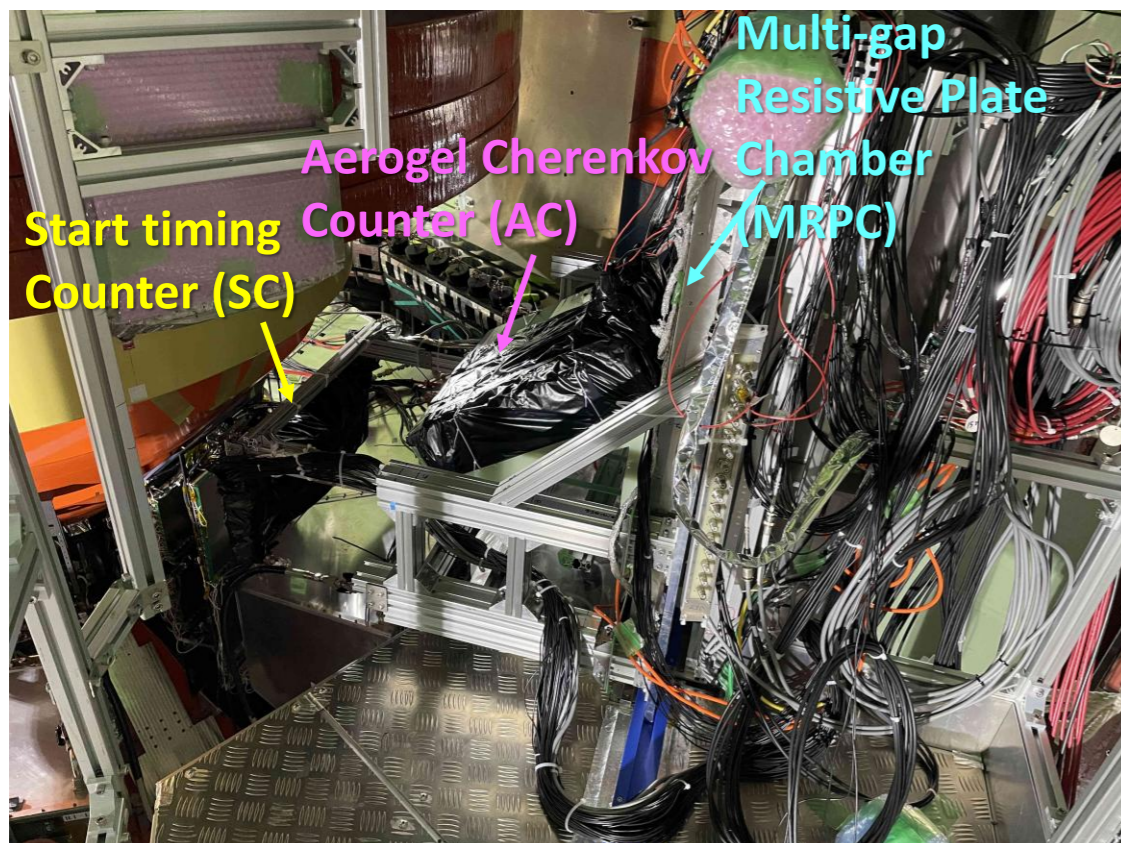

# J-PARC E88 2nd Commissioning and Outlook

Commissioning with 1/3 detector module in E16  
(2026 Nov or early 2027)

- Performance test of **kaon identification system**
- Kaon tracking and  $\phi \rightarrow \mathbf{K}^+\mathbf{K}^-$  invariant mass reconstruction
- Streaming DAQ(AMANEQ) test compared with HUL-HRTDC

This commissioning is essential for **the realization of J-PARC E88**. (earliest around 2028)

Toward **a definitive understanding of chiral symmetry restoration in nuclear matter!**

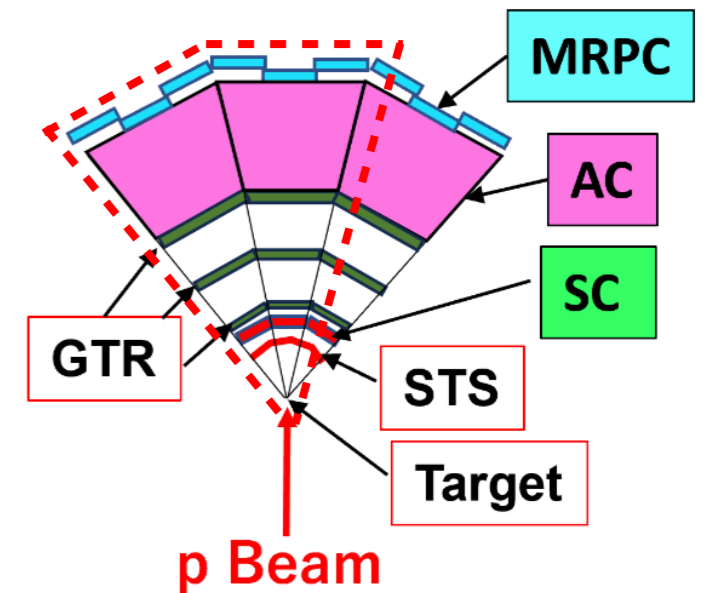

(View from MRPC side)

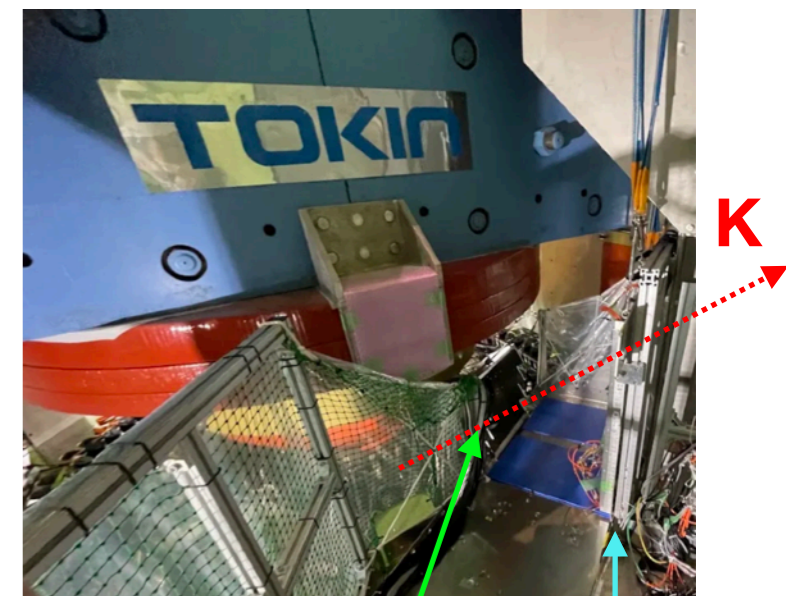

SC/AC MRPC

# Summary

---

- J-PARC E88: Study **in-medium modification of  $\phi$  mesons** via  $\phi \rightarrow \mathbf{K}^+\mathbf{K}^-$  reaction.
- The  $\phi \rightarrow \mathbf{K}^+\mathbf{K}^-$  channel provides complementary information to  $\phi \rightarrow \mathbf{e}^+\mathbf{e}^-$  and enables polarization-dependent studies.
- Development of a high-performance **kaon identification system** (MRPC, SC, AC)
- A commissioning run with a 1/3 detector module is planned in E16

# BACKUP

---

# Intermediate Silicon Tracker (INTT)

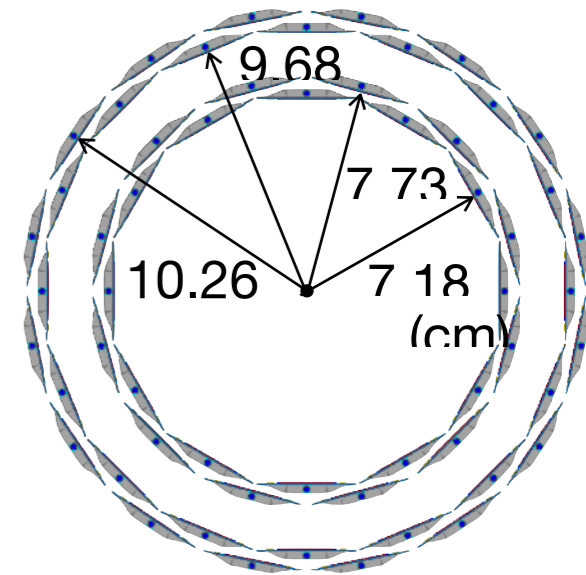
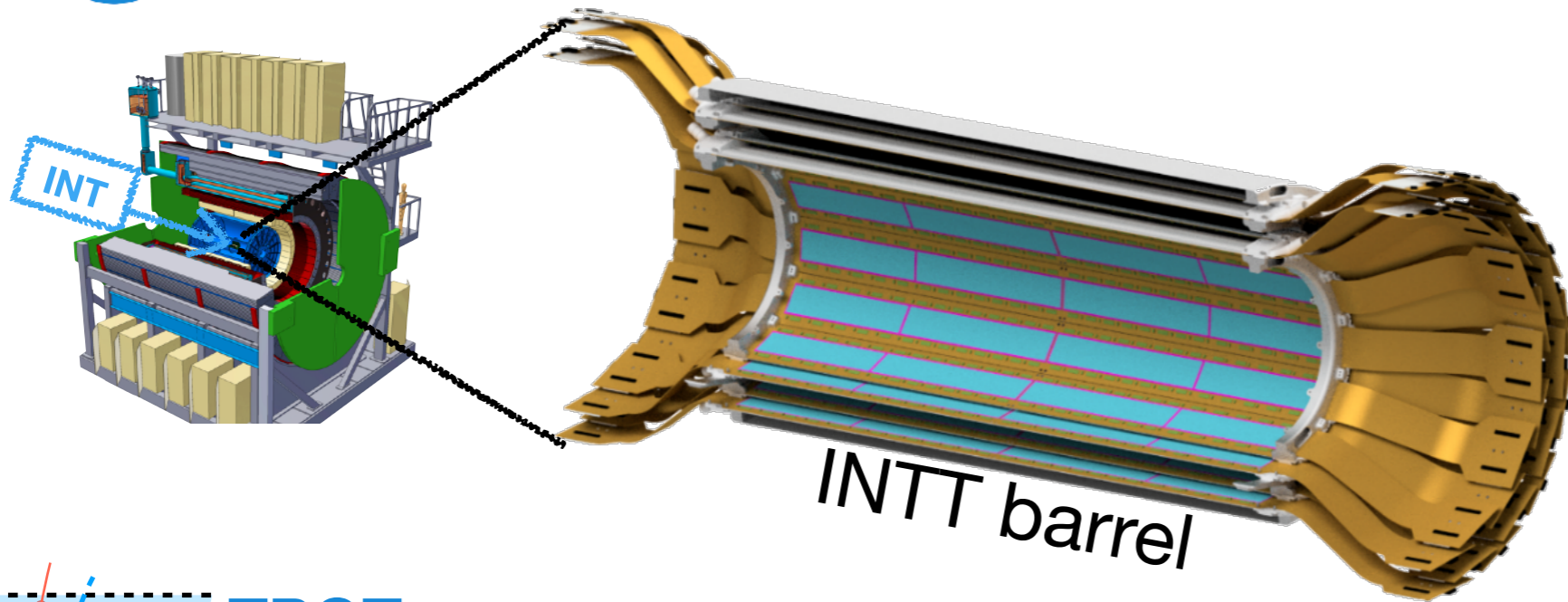

Cross-section of the INTT barrel

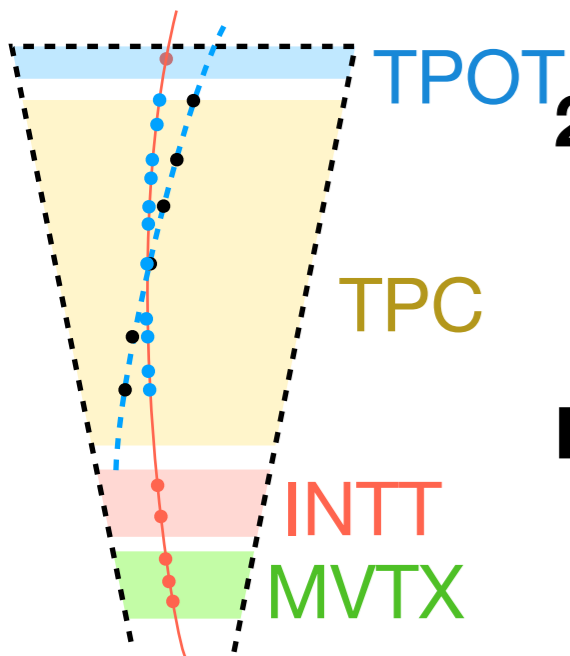

## 2 layers of barrel detector with silicon strip sensors

- Full azimuthal angle coverage in the midrapidity region  $|\eta| < 1.1$
- Low radiation length  $X/X_0 < \sim 1.1\%$  / ladder
- 360k channels in total

## Roll of INTT

- Taking hits b/w MVTX and TPC for better tracking performance.
- Rejection of pileup background using good timing resolution of  $< 1$  bunch-crossing. (MVTX and TPC work at the order of  $\mu\text{s} - 10 \mu\text{s}$ )



# INTT Ladders: Design

- 56 ladders in total
  - 12 × 2 ladders (inner barrel)
  - 16 × 2 ladders (outer barrel)
- 56 readout chips / ladder
- 128 strips / readout chip
  - strip type-A: 78 μm × 320 μm × 16 mm
  - strip type-B: 78 μm × 320 μm × 20 mm

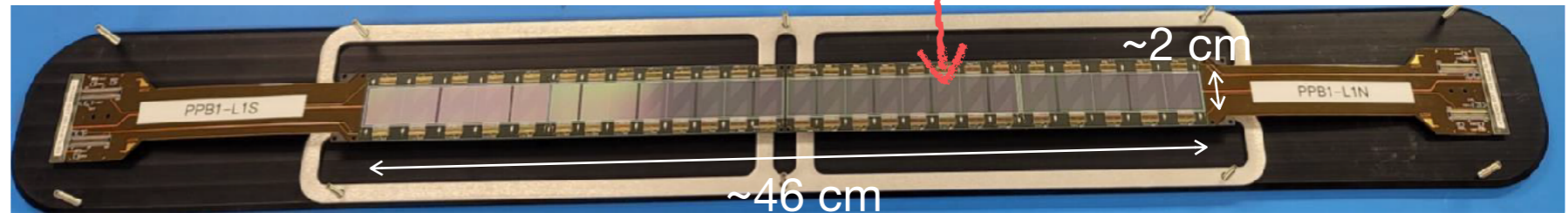
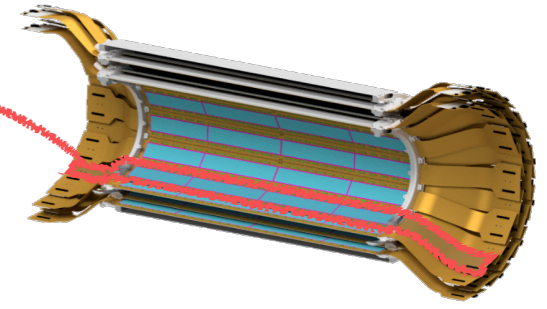

INTT ladder

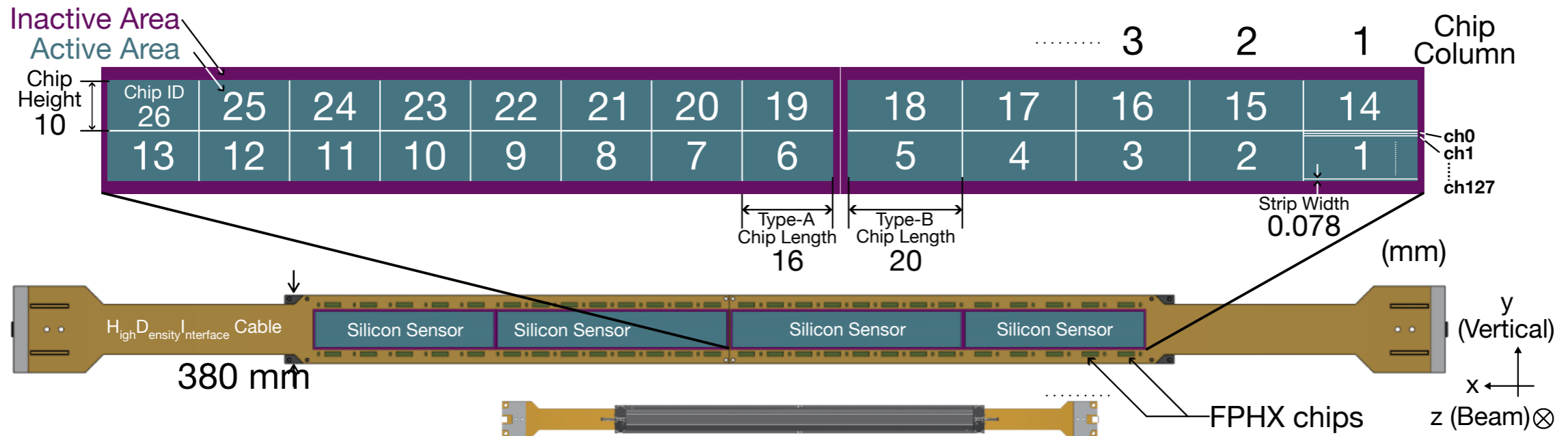
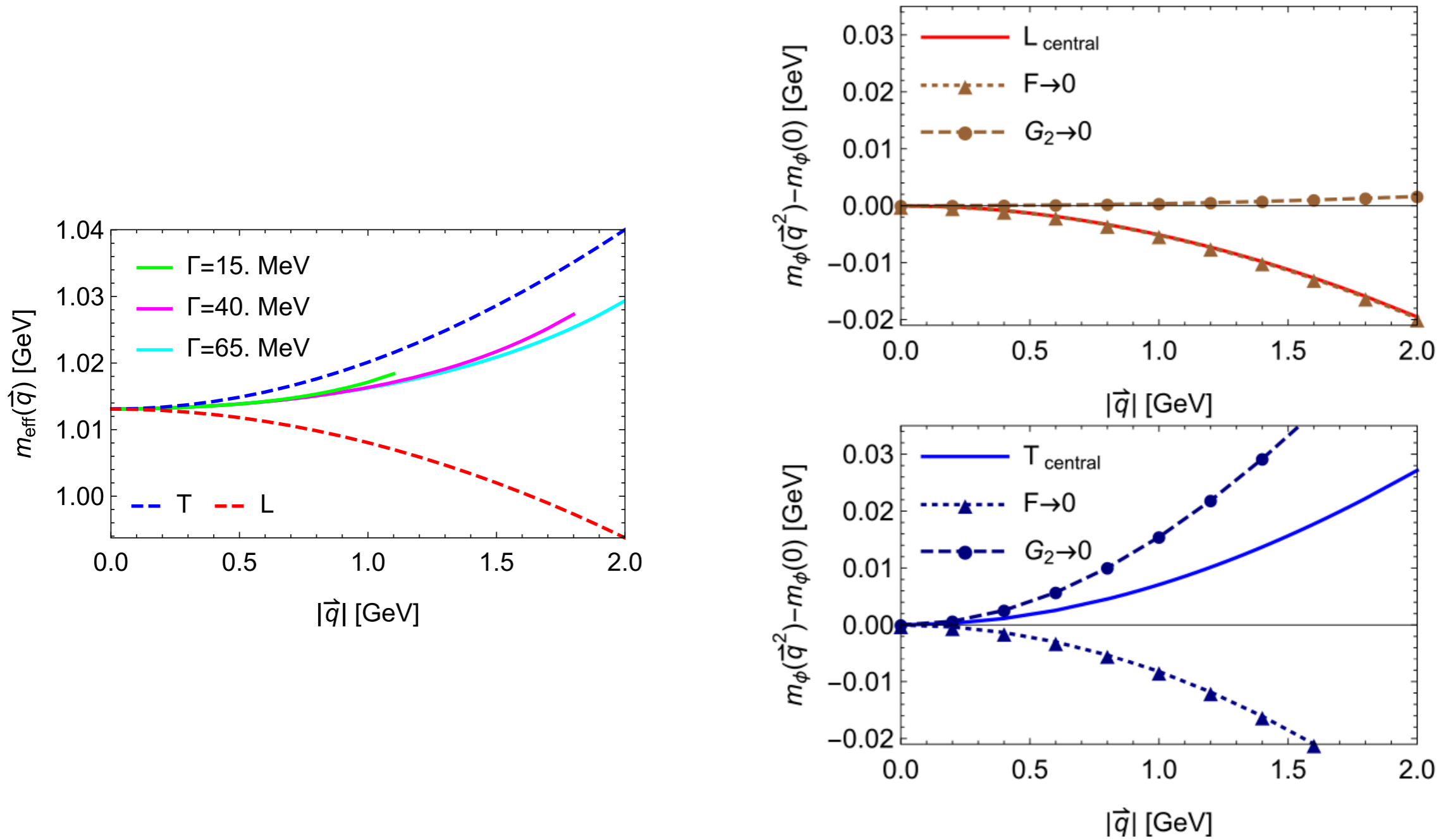

Table 4: Expected  $\phi \rightarrow K^+K^-$  yields in p+C and p+Cu for 30-day run with Configuration A, and expected  $\phi \rightarrow e^+e^-$  yields in p+C and p+Cu for 160-shifts in E16 Run1.

	$\phi \rightarrow K^+K^-$		$\phi \rightarrow e^+e^-$	
	p+C	p+Cu	p+C	p+Cu
Total	159k	262k	12.5k	14.8k
$\beta\gamma < 1.25$	72k	113k	1.4k	1.8k
$1.25 < \beta\gamma < 1.75$	84k	146k	2.3k	3.0k
Overlap $y - p_T$ ( $\beta\gamma < 1.25$ )	65k	100k	98	150
Overlap $y - p_T$ ( $1.25 < \beta\gamma < 1.75$ )	83k	143k	130	180



**Fig. 3.** The effects of the non-scalar condensates  $F$  and  $G_2$  on  $\Delta m_{\phi}(\vec{q}^2)$ . The upper (lower) plot shows the behavior of the longitudinal (transverse) mode.

# QCD sum rule results

They provide mass of  $\phi$  meson vs  $\sigma_s$  (strangeness sigma term)  
 The  $\sigma_s$  indicates how much  $\langle \bar{s}s \rangle$  is reduced in nuclear matter.

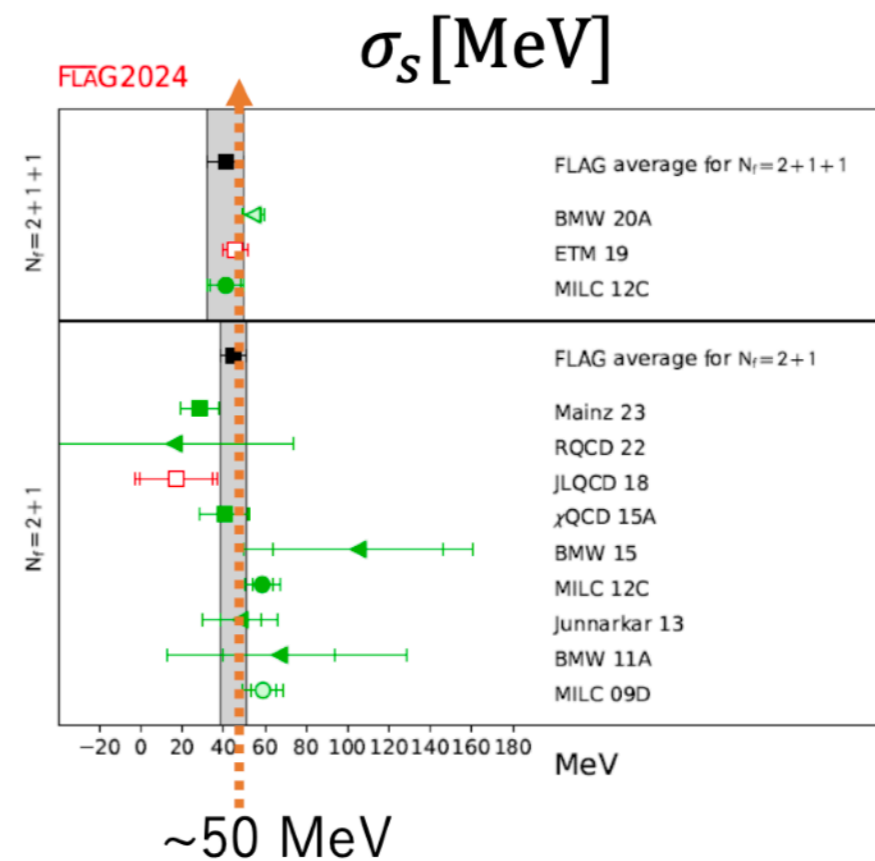
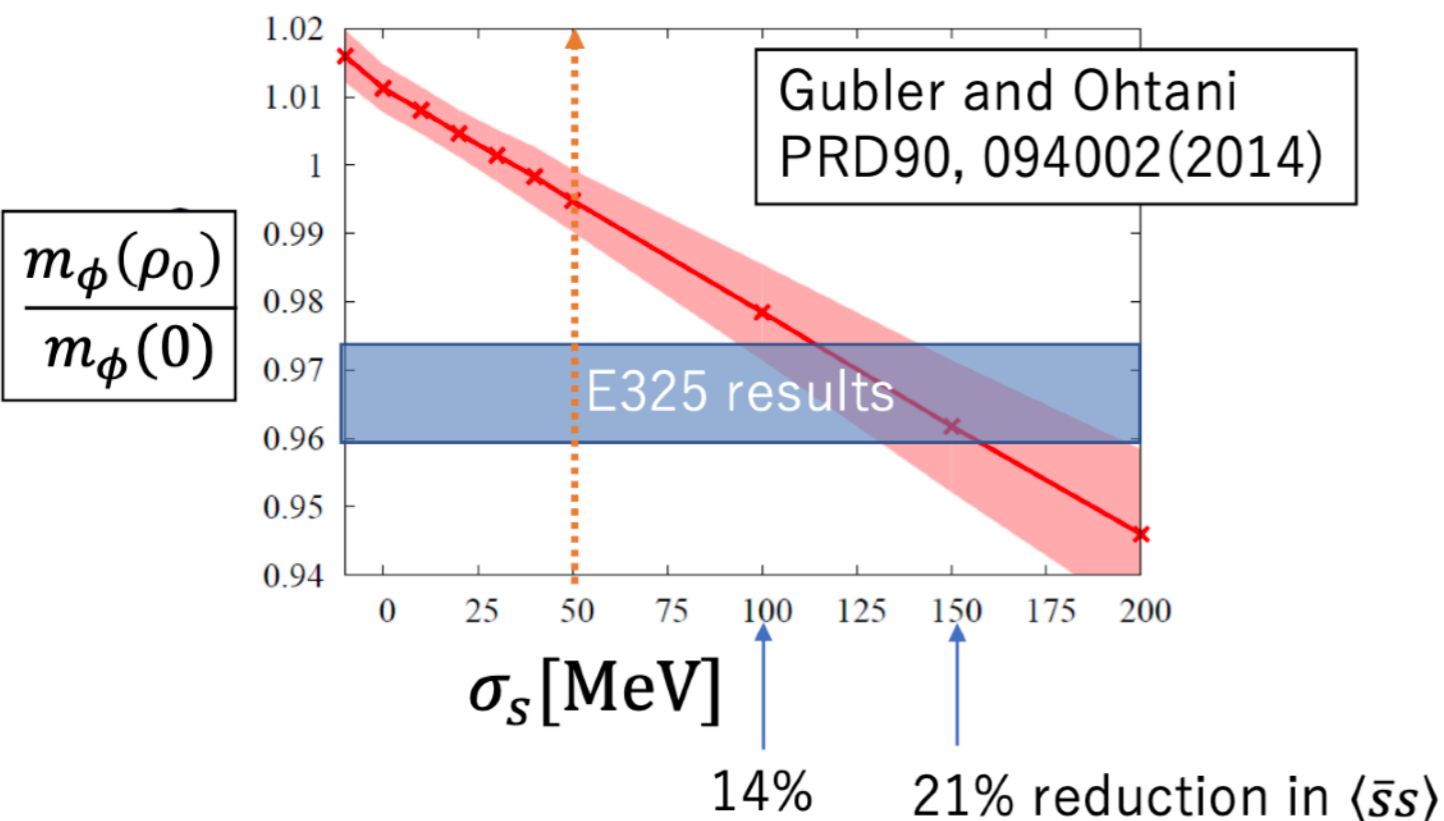

$$\langle \bar{s}s \rangle_\rho = \langle \bar{s}s \rangle_0 + \frac{\sigma_s}{m_s} \rho$$

$$\sigma_s = m_s \langle N | \bar{s}s | N \rangle \quad (= m_s \frac{\partial M_N}{\partial m_s})$$

If one takes  $\sigma_s$  from Lattice and QCD sum rule,  
 Mass reduction should be much smaller. ( $dM \sim 1\%$ )



GTR

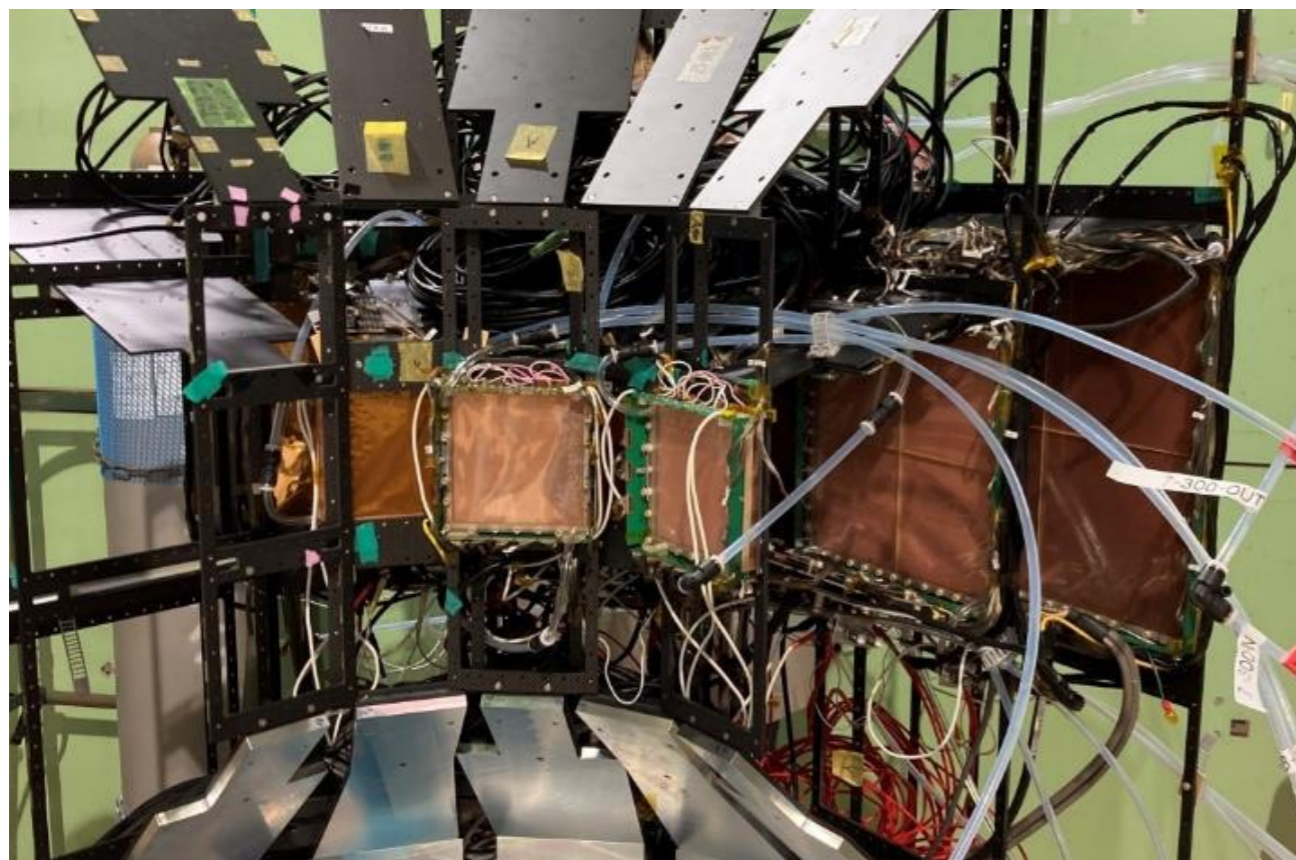

STS

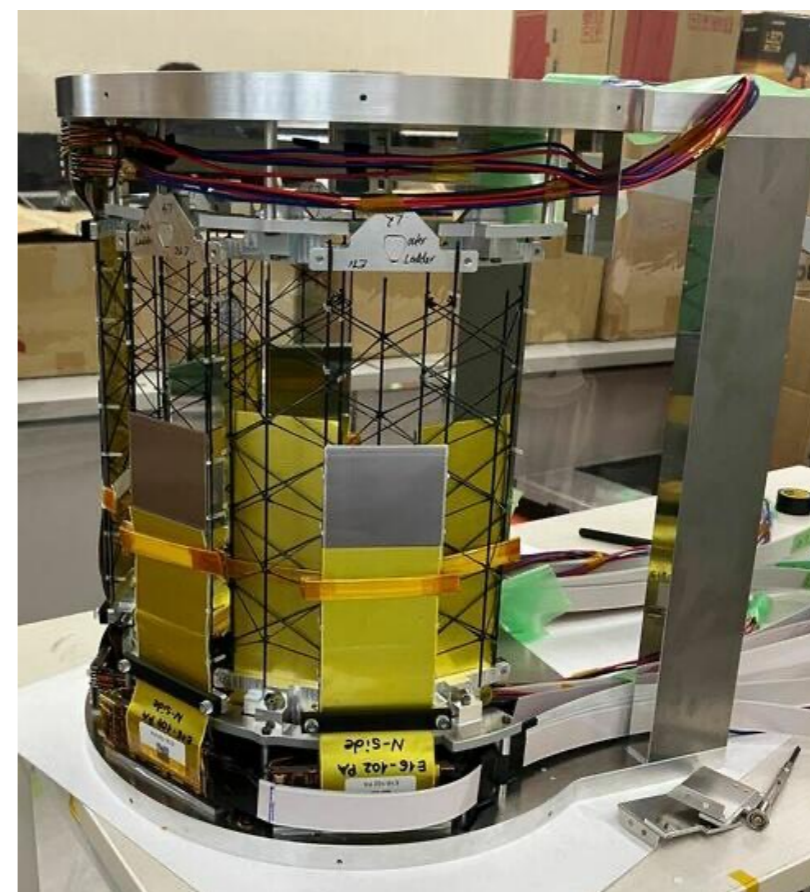

# SC Timing Resolution & SC Hit Position Uniformity

**Best timing resolution:**  $\sigma_T = 79 \pm 3 \text{ ps}$

**Uniform timing resolution ( $\sim 80 \text{ ps}$ ) over full length,  
gain variation  $< 5\%$**

Timing resolution vs position

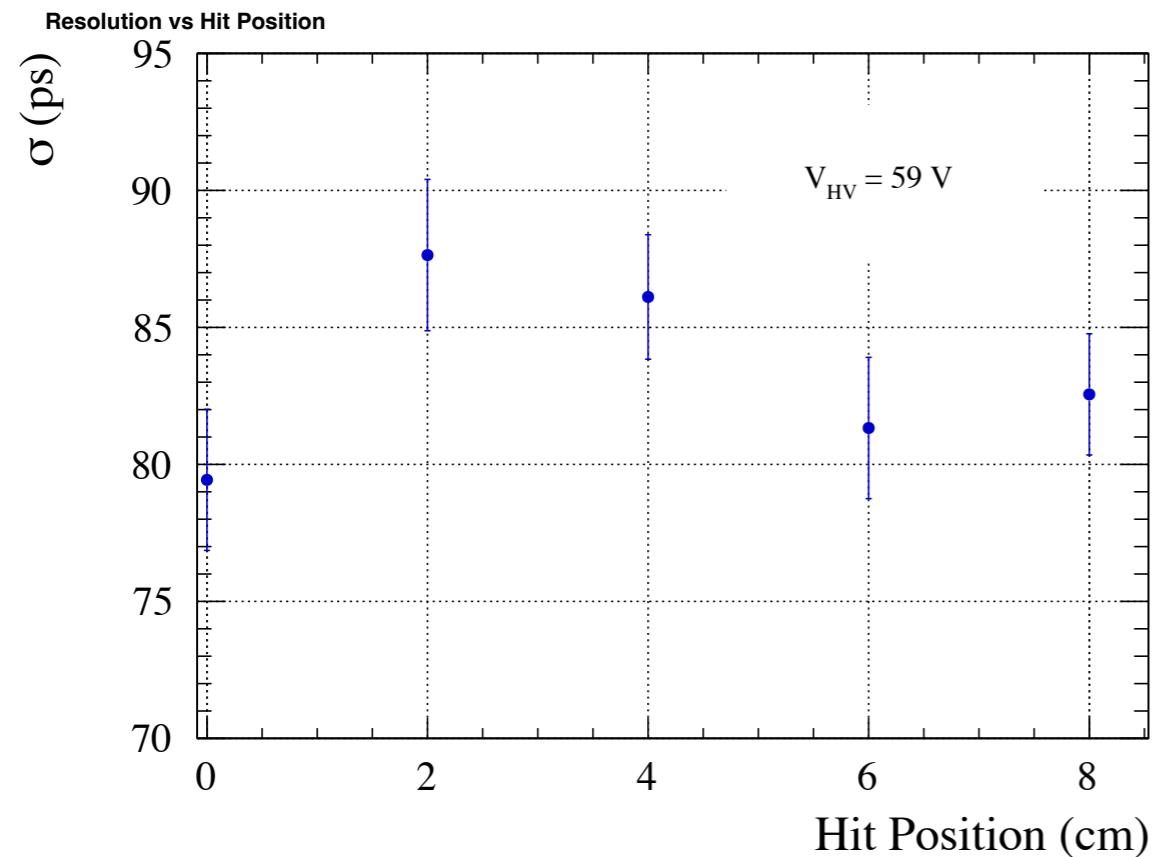

Light attenuation measurement

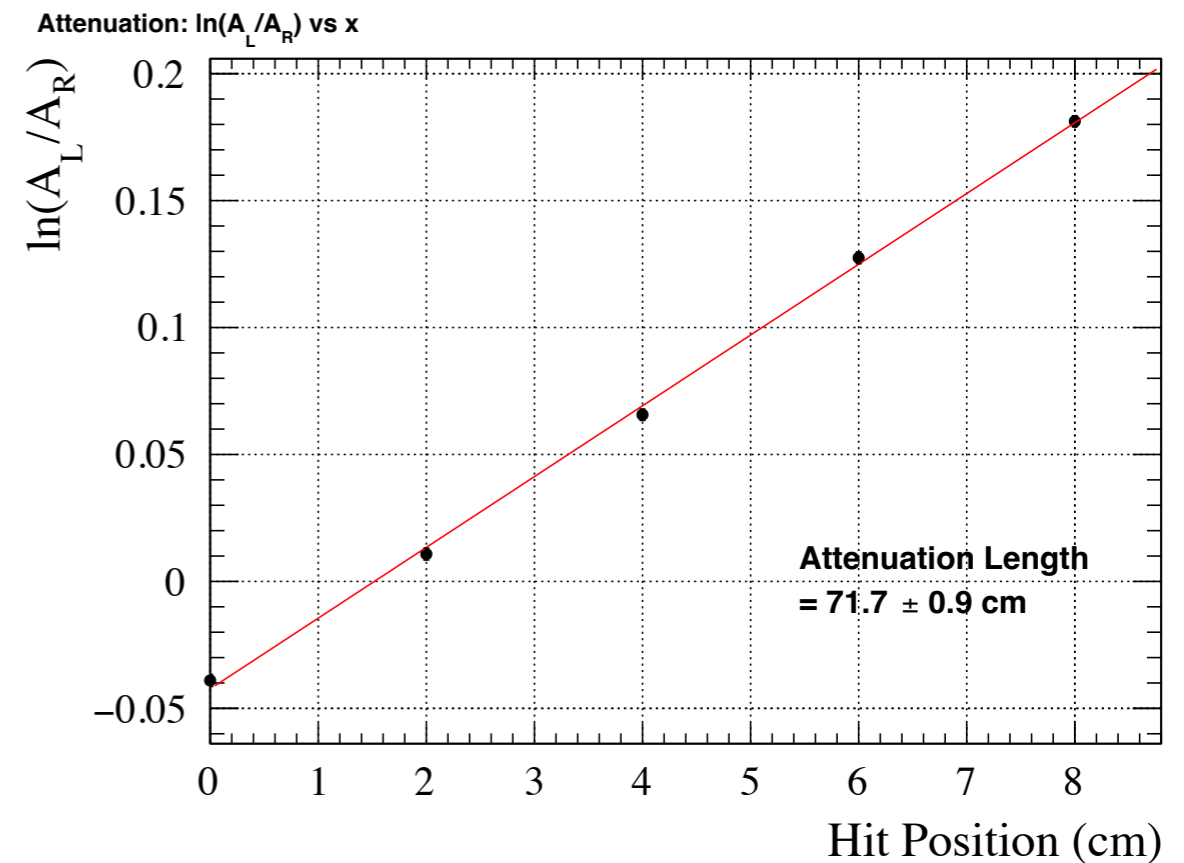

Attenuation length:  $71.7 \pm 0.9 \text{ cm}$

# MRPC Timing Resolution

## Best timing resolution:

$$\sigma_T = 81 \pm 3 \text{ ps with } V_{MRPC} = 6.99 \text{ kV}$$

## Previous prototype test

Timing improves with increasing temperature:

~over 10% improvement from 295 K → 315 K

**295 K, 300 K, 305 K, 310 K, 315 K**

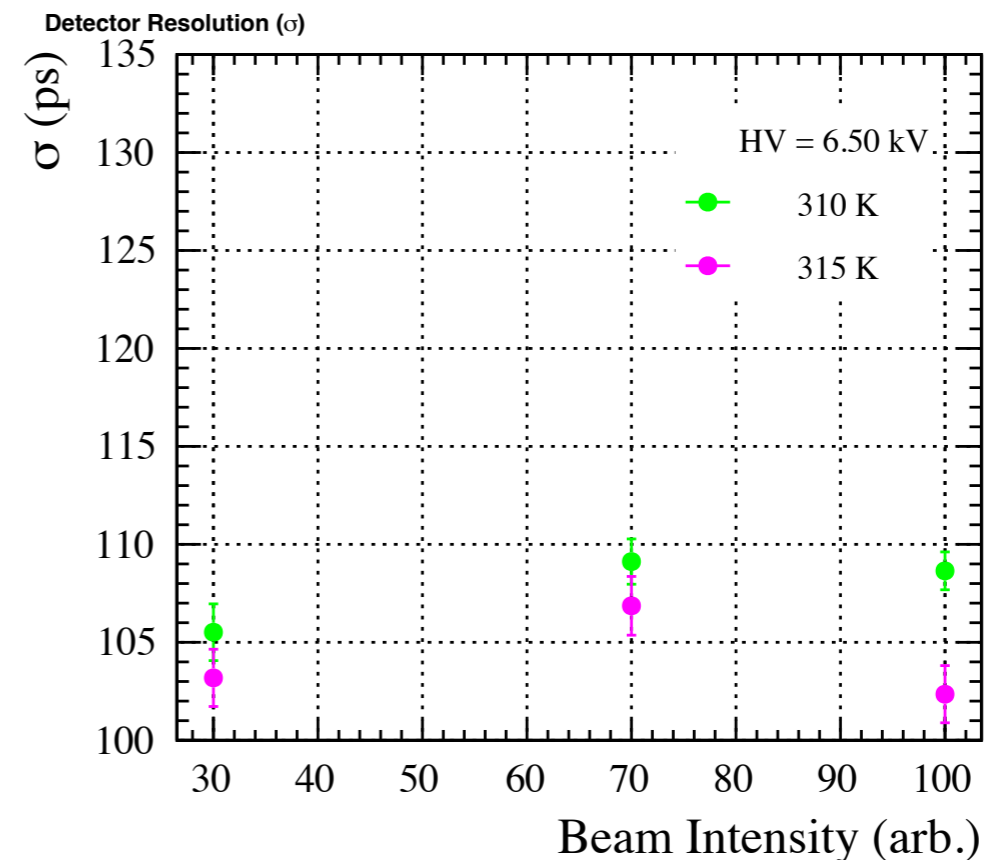
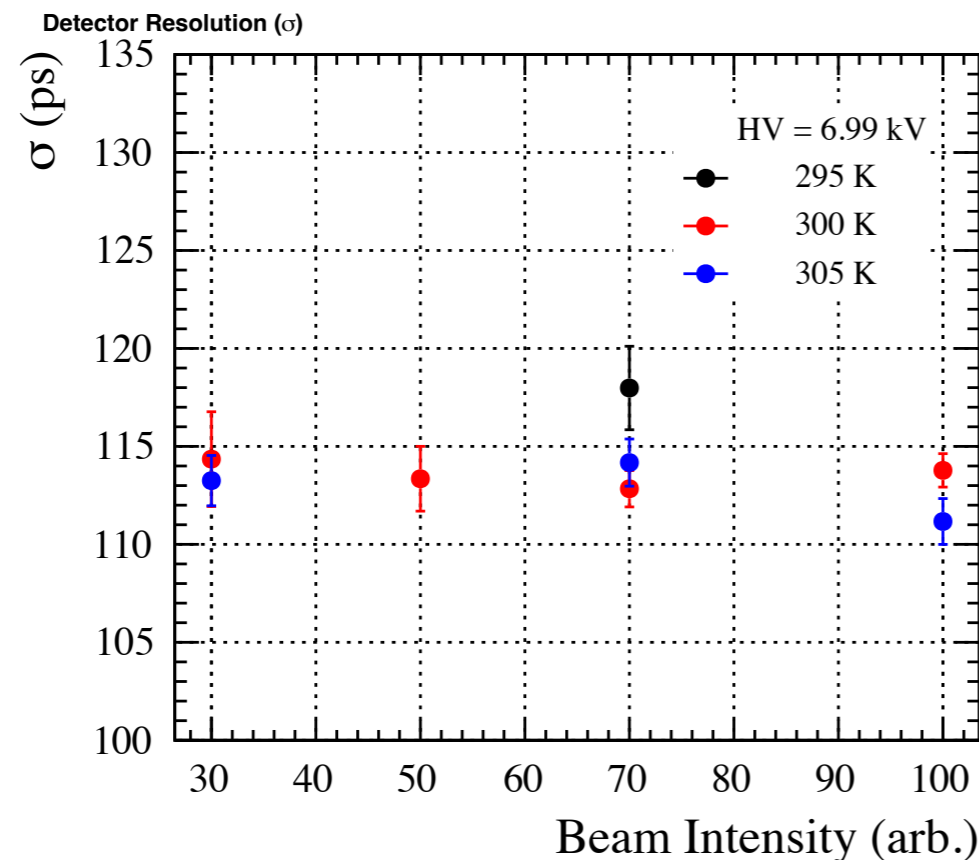

# Results of MRPC test: MPPC HV&threshold Dependency

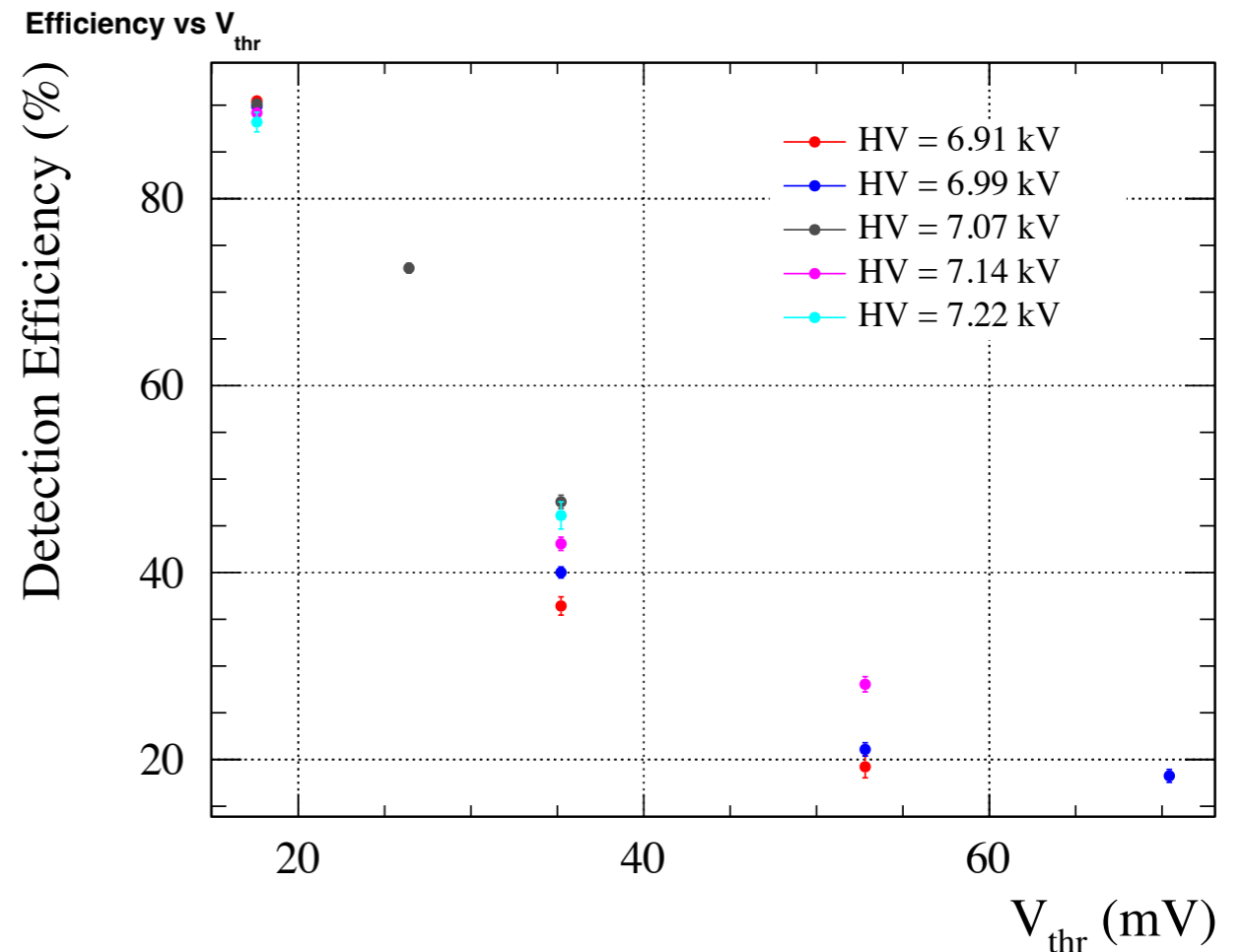
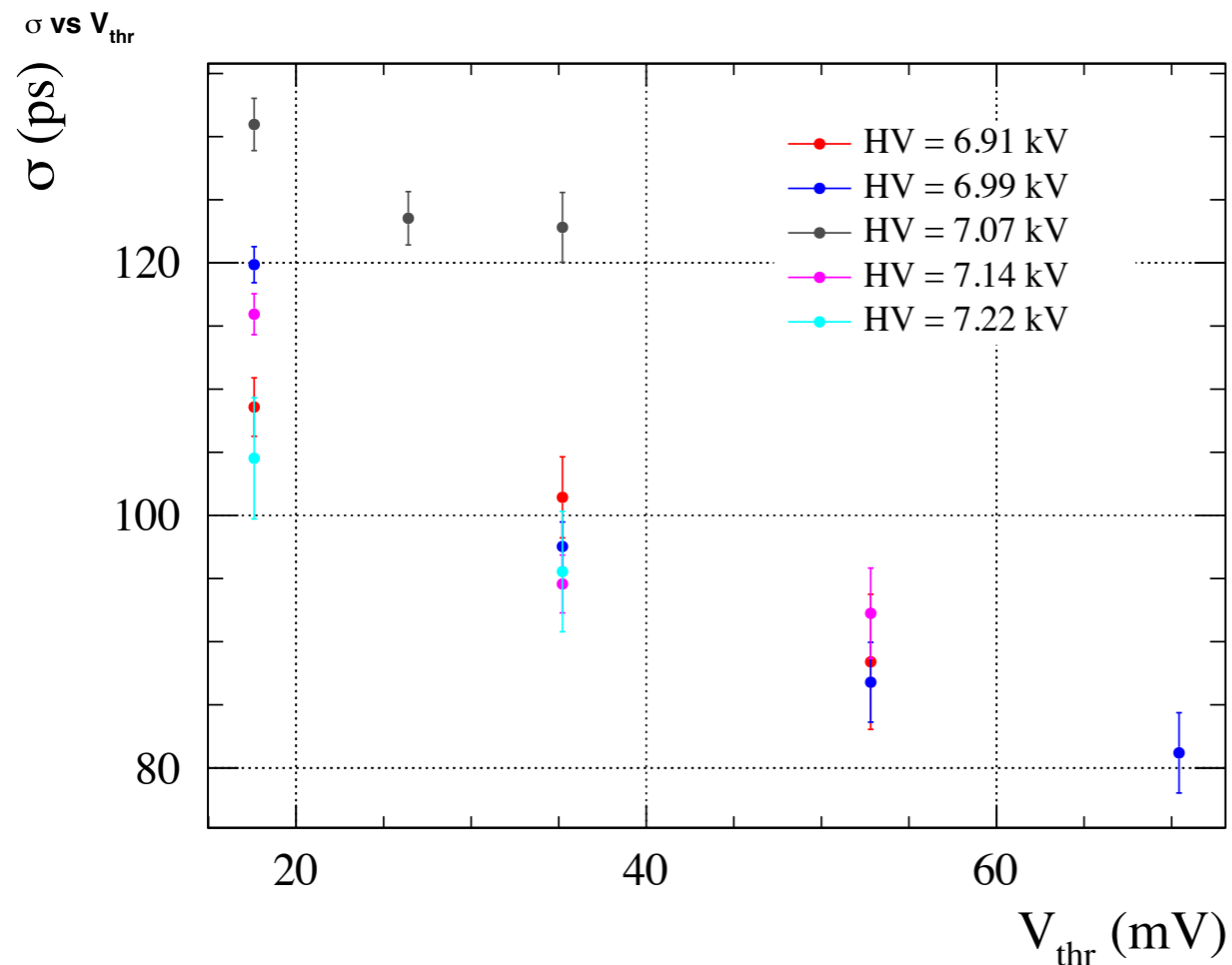

**The best condition:  $\sigma_T \sim 81 \pm 3$  ps with  $V_{MPPC} = 6.99$  kV (control input: 9.7 V) and  $V_{thr.} = 70$  mV**